

MTC - MultiControl

Controller or Speed Selector for EC-Fans
Software 2.4



BA417AB03/16/A

Content

Content	2
1 General Information	3
2 Safety	3
3 Definition of Qualified Personnel	4
1 Normal Operation / Scope of validity	4
1.1 Normal operation	4
1.2 Scope of validity	4
2 Description	5
2.1 General and Operation	5
2.1 ON/OFF Switch and Key Assignment	5
2.2 Technical Data	6
2.3 Terminal Allocation	7
2.4 Scope of delivery of the Control	8
3 Installation	9
3.1 Installation instructions	9
3.2 Assembly/Initial Operation	9
3.3 First Configuration	10
4 Parameter and Settings	12
4.1 Parameter List	12
4.2 Parameter Control mode	15
4.3 Parameter List 4-stage speed specification	17
4.4 Time Program	19
5 Storage, Transport	19
6 Maintenance, Servicing	20
7 Accessories and Field Device	20
8 Copyright	21
9 Customer Service, Manufacturer's address	21
10 Commissioning Protocol	22
11 Notes	22

1 General Information

This operating manual contains important technical and safety information.

Read this operating manual carefully before unpacking, mounting, commissioning and for other maintenance and service activities on the control device.

It must be ensured that the operating manual is accessible and available during the operation of the EC-Fan with the Multi Control.

An operator of the EC-Fan with the Multi Control must read the operating manual carefully and understand the information before unpacking, mounting, commissioning and for other maintenance and service activities on the control device.

If there are further questions regarding installation, operation or maintenance please consult our sales department.

2 Safety

The following icons show certain hazards or give advice for the safe operation.



Caution! Danger zone! Safety advice!



Hazardous electricity or high voltage!



Caution! Hot surface!



Important advice, Information



This MultiControl carries hazardous electric current and controls rotating, mechanical parts to a EC-Fan. Death, grave physical harm or substantial damage to property may occur, if the instructions of the operation manual are not observed.



Only qualified personnel should work on the MultiControl. These personnel must be familiar with all warning instructions and actions to install and use the MultiControl according to the manual. MultiControl The successful and safe operation of the unit is dependent on the correct transport, assembly use and maintenance.



Do not install the unit in places with current conducting dust, corrosive or flammable gases, humidity, rain or excessive heat or pollution.



The EC- Fans with the MultiControl is not protected against explosion (Directive 94/9/EG).



It is strictly forbidden to perform work on live electrical equipment. Contact with dangerous voltage is possible.



The wiring of the MultiControl with the Installation housing or assembly with the article number H42-91000, H55-00072 and H55-00073 must be carried out according to the connection schematic.

Wrong connections lead to the destruction of the unit. Deficiencies of electrical installations/assemblies/equipment must be repaired immediately. If there is imminent danger do not operate the Multi Control /assembly in defective condition.

3 Definition of Qualified Personnel

According to the operation manual and the warning instructions, qualified personnel are persons who are familiar with installation, assembly, initialization and operation of the product and have the following qualifications:

- Training or instruction i.e. authorization to switch power and equipment on and off, to ground and to mark circuits and devices according to the standards of safety engineering.
 - Training or briefing in maintenance and use of appropriate safety equipment according to the standards of safety engineering.
 - Training in first aid.

1 Normal Operation / Scope of validity

1.1 Normal operation

The MultiControl with the Installation housing for operating EC- fans with the article number H42-91000, H55-00072 and H55-00073 is exclusively developed and intended for the tasks as control, regulation and monitoring of Rosenberg EC- Fans. Other uses or uses above their intended use are prohibited unless contractually agreed upon. The manufacturer is not liable for damages which might occur by use of the product for something other than its intended purpose. The user assumes all risks.



It is part of the intended use to obey the operations described in this manual for the assembly, operation and maintenance.



We point out that this operation manual is only valid for the MultiControl with the Installation housing for the operation of the EC- Fans with article number H42-91000, H55-00072 and H55-00073 and in no case for the complete system!

1.2 Scope of validity

The scope of validity of this manual includes the following control versions or the assembly with the article number H42-91000, H55-00072 and H55-00073:

- Temperature-, CO₂-, Pressure, Volume flow or humidity control with control mode for a Rosenberg EC- fan inter alia in connection with a damper actuator (spring return), frost thermostat, Filter alarm or similar
- 4-speed step switch for a Rosenberg EC-Fans
- Time program

2 Description

2.1 General and Operation

The **MultiControl with the Installation housing Article number H42-91000, H55-00072 and H55-00073**: is a PID/XP multi-function controller with integrated display. The weekly timer has a Day/Night set point and is able to switch ON/OFF the fan. Furthermore it is compatible with a number of different input signals, e.g. pressure, flow, temperature, CO₂ and humidity. Alternatively, the software can be switched to 4-speed selector of Rosenberg EC- Fans.

The **MultiControl** (Model E Regulate) is equipped with 2 regulators with 0-10VDC output and an **integrated MODBUS Slave RS485 Interface**.

Predefined programs facilitate the initial settings. Via integrated Micro-SD Card- Interface programs/settings can be easily programmed. The maximum storage capacity of the Micro_SD Card cannot exceed 2GByte.

2.1 ON/OFF Switch and Key Assignment

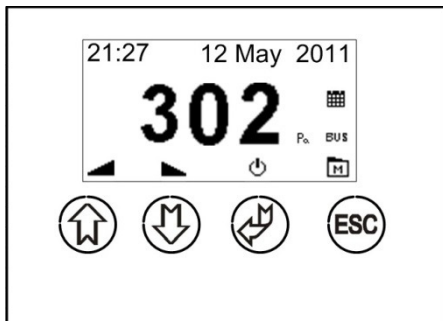

Display: Set point application

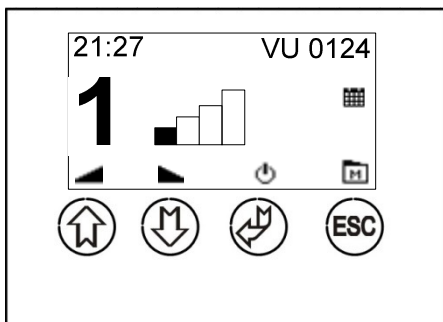

Display: 4-stufige Anwendung

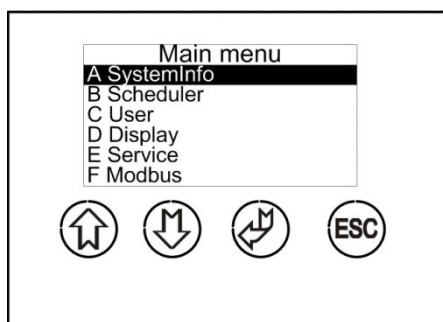

With the **ESC** key you get from the start display to the menu display

Symbol	MENU DISPLAY Function
	„ENTER“, changing to set point when the actual value is displayed / <u>At 1 second : for ON/OFF</u> <u>At 3 second: press for extended operating</u>
	Set point / Higher speed (arrow up)
	Set Point / Reduce speed (arrow down)
ESC	Remove / back

See parameter E42 to be set for external switch

ON- OFF

Symbol	START DISPLAY Function
	Enter
	Increase (arrow up) increase set point
	Decrease (arrow down) reduce set point
ESC	Remove / back

Password

The **Password** for the menu **D Display** or **E Service** is **5550**

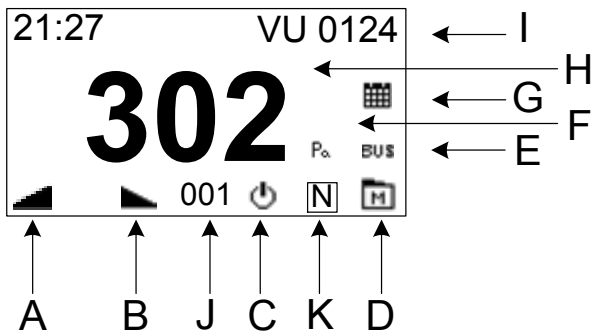

- A) Increase of set point / speed stage
- B) Decrease of set point / speed stage
- C) ON/OFF
- D) Main Menu
- E) Modbus switched on
- F) Unit (e.g. Pascal)
- G) Timer switched on
- H) Set point (SET) / speed stage (0-4)
- I) Time, Date, Company name, Alarm (optional-ly)
- J) Display Set point: Day [N], Night [A], Motion detector [P]



When the controller is switched on for the first time (voltage) it will ask for the function. Different predefined parameterizations are available. A subsequent change is under (D4) possible.

2.2 Technical Data

	24V Version	230V Version
Power supply:	15-30VDC or 24VAC +-15%	230V AC ±10%
Enclosure:	Max 1A	16A
Power Consumption:	Max 2,4W	Max <1W
	Attention: Observe sensor consumption	Attention: Observe sensor consumption
Protection class:	IP 40 / IP 54	IP 40 / IP 54
Operating temperature		
Relay:	0 - 60°C	0 – 50°C
0-10VDC Output (Vout1, Vout2)	0-10,0V DC Max 10mA	0-10,0V DC Max 10mA
0-10VDC Input (Vin1, Vin2)	7k Ohm Input impedance	7k Ohm Input impedance
Micro- SD- Card	max. 2GByte	max. 2GByte
Allowed cable length 0-10V outputs and sensors	Max. 100m with 0,75mm ² cross section	Max. 100m with 0,75mm ² cross section

2.3 Terminal Allocation

24V

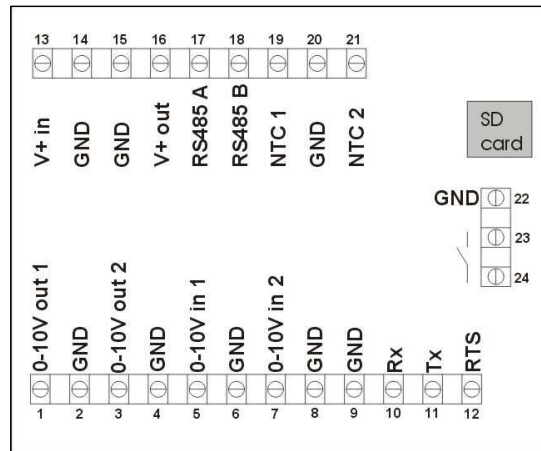

Terminal allocation 24V Version

Contact

1 + 2 (Vout1)

3 + 4 (Vout2)

5 + 6 (Vin1)

7 + 8 (Vin2)

10 + 11

13 + 14

15 + 16

15,17 + 18

19 + 20

20 + 21

23 + 24

2,4,6,8,9,14,15,20,22

Micro- SD- Card

Allowed cable length 0-10V outputs and sensors

Description

0-10V Output 1

0-10V Output 2

0-10V Input 1

0-10V Input 2

Not used

Power Supply MultiControl

Supply external sensor

RS 485 MODBUS RTU

NTC1 Temperature Sensor

NTC2 Temperature Sensor

/Alarm Input

/Motion detector Input

Relay output

GND

max. 2GByte

Max. 100m with 0,75mm² cross section

Note

max. 10mA

max. 10mA

7k Ω Input impedance

7k Ω Input impedance

15-30VDC or 24VAC

15-30VDC or 24VAC

Slave

22k Ω NTC

22k Ω NTC / Switch

Potential-free, programmable, 24VDC NO, 3A AC1

max. 2GByte

Max. 100m with 0,75mm² cross section

230V

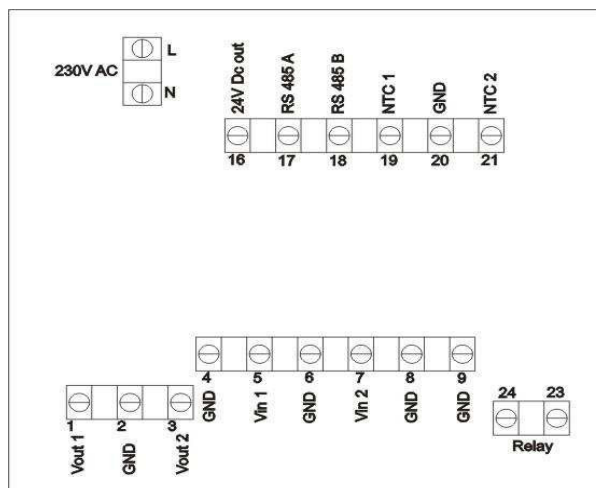

Terminal allocation 230V Version

Contact	Description	Note
1 + 2 (Vout1)	0-10V Output 1	max. 10mA
3 + 4 (Vout2)	0-10V Output 2	max. 10mA
5 + 6 (Vin1)	0-10V Input 1	7k Ω Input impedance
7 + 8 (Vin2)	0-10V Input 2	7k Ω Input impedance
L + N	Power Supply MultiControl	230V AC ±10%
16	Supply for external sensors	+24VDC max 100mA SELV
17 + 18	RS 485 ModbusRTU	Slave
19 + 20	NTC1 Temperature Sensor	22K Ω NTC
21 + 20	NTC2 Temperature Sensor	22K Ω NTC / Switch
	/Alarm Input	
	/ Motion detector Input	
23 + 24	Relay output	Potential-free, programmable 5A-AC1, 250VAC
2,4,6,8,9,20	GND	---
Micro- SD- Carte	max. 2GByte	max. 2GByte
Allowed cable length 0-10V outputs and sensors	Max. 100m with 0,75mm ² cross section	Max. 100m with 0,75mm ² cross section



The allocation of the terminals on the MultiControl with the Installation housing and on the terminal blocks must be performed exclusively according to the valid wiring.

The electric potentials must be observed when mounting and wiring. Incorrect wiring may damage the electronic circuit or lead to wrong logically program routine. If after reading the operating instructions and the circuit diagram there are still some questions regarding installation, operation or maintenance please contact the Rosenberg Ventilatoren GmbH.

2.4 Scope of delivery of the Control

- Control unit MultiControl with the Installation housing article number H42-91000, H55-00072 and H55-00073
- This operating instruction
- A wiring diagram is **not** included in the scope of delivery
- Cable and Installation material are **not** included in the scope of delivery

Rosenberg Ventilatoren GmbH can make upon request and against expense calculation wiring diagrams. Recommendations on cable and cable lying (max. length) and initial operation should be made local.

3 Installation

3.1 Installation instructions

This operating manual must be read carefully and the safety instructions, technical properties and limits must be taken into account during the dimensioning and design

The properties in order to maintain the IP-Protection according EN 60529 (Protection provided by housing) shall be taken into account.

Main switch must be provided and must be installed in an easily accessible way.

The supply cable must be connected on the main switch, which is suitable for the disconnection of the supply voltage and for operation interruption of the EC-Fan and the der MultiControl in the installation housing.

See properties voltage and operating current for the assessment of the main switch. An automatic voltage interruption at overcurrent and residual current shall be provided.

An all-current sensitive type for security against hazardous body current is necessary at the Residual Current Circuit Breaker (RCD).

Marking on the FI- fault-current circuit breaker:

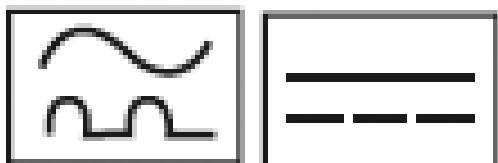

3.2 Assembly/Initial Operation

Please follow the correct sequence:

- Step 1: Stable mechanical EC-Fan installation on the desired place.
See the EC-Fan equipment manual and planning documents.
- Step 2: Check the article number of all delivered components with the delivery note data, with the technical data, planning data and also with the circuit diagram to its accuracy.
Damages and costs through mistakes can be avoided.
- Step 3: Unpack all components and check for damages. Damages should be immediately reported to the supplier or the manufacturer Rosenberg Ventilatoren GmbH. Defected or damaged components may not be taken into operation.
- Step4: Correct and safe electrical installation of the control device MultiControl with the Installation housing article number H42-91000, H55-00072 and H55-00073 by compliance with the appropriate requirements and directives.
For example EN 60204-1 with a continuous protective ground conductor system for the purpose of equipotential bonding and for automatic shutdown of the supply voltage to avoid dangerous situations.
Install the electrical components only when all mechanical ventilation system party is firmly installed on the intended place.

A flush-mounted box can be helpful, in which the cable feeding to the MultiControl is made from below.



The electrical connection can only be done by an authorized electrician having regard to the VDE-Rules as well as the directives of the local energy supplier and valid standards. For the connection you must proceed exactly according to the circuit diagram and wiring diagram.

All screw connections must be controlled before initial operation and, if necessary, tighten up.

Inspect the supply cables before installing for voltage. Start with the electrical work only after you have safeguarded the electrical protection against restarting and when the supply cables are stress-free.

Attention: The EC- Fans can lead after the connection to the supply line dangerous electrical tensions.

Step 5: Setting and configuration of the control device MultiControl with the installation housing article number H42-91000, H55-00072 and H55-00073 for the operation of the EC- Ventilator at the operating point.

Step 6: The EC-Fans must at each speed rotate freely. This prevents consequential damages at the bearings



The wiring of the control device MultiControl with the installation housing article number H42-91000, H55-00072 and H55-00073 and of the electrical accessory must be made according the wiring diagram. Wrong wiring can permanently destroy the electronic or lead to wrong logical program routine



The operator is obliged to operate the device only in perfect condition and to check it regularly. Danger points that can arise between Rosenberg Ventilatoren GmbH devices and customer supplied equipment must be secured by the operator!

3.3 First Configuration



When the controller is switched on for the first time (voltage) it will ask for the function. Different predefined parameterizations are available. A subsequent change is under (D4 reset to factory setting) possible.

Follow these operating steps. From the main menu you can get to menu display with the „ESC“. Button. Drag the highlighted bar to the „Display“ line. This Display Menu is password-protected with the password 5550. Chose the parameter „06 Model select“ You can see the following options from the Software Version 2.4.

A subsequent change is possible under the parameter „Model select“ **D6**.

Selection for „controller“ is

- 01 Temperature Output 0/10V,
for example water valve and Pump
- 02 Temperature 1 heating element, Output Pulse Vout1 0/10V
for example control of electric heating through fixed resistor
- 03 Temperature 2 heating element, Output Pulse Vout1 Vout2 [0/10V]
for example control of electric heating through fixed resistor
- 04 Temperature 3 heating element, Output Pulse Vout1 Vout 2 Relays 0/+24V
for example control of electric heating through fixed resistor

- 05 Constant speed (Volume flow), Output 0/10V
for example control of EC- Fan with speed sensor
The Volume flow must be manually converted in flow velocity. For this purpose the cross-section must be used. The correct sensor must be chosen.
- 06 Constant pressure / Volume flow, Output 0/10V
for example control of EC- Fan with pressure sensor, or Volume flow with pressure sensor when setting the k-Factor >0
- 07 Constant humidity (Reduction), Output 0/10V
for example control of EC- Fan with humidity sensor
- 08 Constant CO₂ (Reduction), Output 0/10V
for example control of EC- Fan with CO₂ Sensor
- 09 CO₂ and Temperature, Output 0/10V
for example control of EC- Fan with CO₂ and Temperature Sensor
If CO₂ or Temperature increases, the output enhanced
- 10 Temperature and Temperature, Output 0/10V
Temperature-control of a room
A sensor at the inlet reduces the air supply at outdoor temperature



A subsequent change is possible under the parameter „Model select“ **D6**.

Selection for „manual control“ is

- 01 ON/OFF To switch between 2 voltage values (low/high).
Both voltage values are configurable, e.g. 0,0/10,0V or 3,5V/8,0V and so on.
Switching of the voltage values with the ENTER-button or with time program, the relay is closed, when switched on
- 02 0-100% For stepless adjustment of the voltage values move the arrow on „smaller“/“bigger“button. The time program is able to normal or alternative set point or stop, if the release of relay is closed, when switched on and when the set value is exceeded.
- 03 0-100% + PIR For stepless adjustment of the voltage values move the arrow on „smaller“/“bigger“button. Time program is not available, a motion detector PIR switches between 2 values the Relay is closed, when switched on and when the set switch value is exceeded.
- 04 0-100% + Speedometer Application for EC- Motors with Speedometer- Signal (speed control).
For stepless adjustment of the voltage values move the arrow on „smaller“/“bigger“button. The time program is able to normal or alternative set point or stop, if the release of relay is closed, when switched on and when the set value is exceeded.
Alarm is displayed when the speedometer signal is missing.
- 05 4-Stage For manual control of 4 definable stages
→ **Attention: other Parameter List**
- 06 2-Stage PIR To switch between 2-stage with connected motion detector PIR

4 Parameter and Settings



Individual displays of the control device MultiControl with the Installation housing article number H42-91000, H55-00072 and H55-00073 were only shown when the respective pre-settings were selected.

The initial operation must be repeated after connecting a new accessory. It may be necessary before disconnecting the accessory to deactivate the corresponding control function

4.1 Parameter List

This parameter in the E Service menu is protected through the password 5550.

Description	Default	Min	Max	Unit
Menu C = User				
C1 Control 1 Set point Day (NORM) Depending of Parameter E1	pressure: 200	pressure: 0	pressure: 5000	pressure: Pa
C2 Calendar switch on/off	OFF	ON	OFF	OFF/ON
C3 Control 1 alternative Set point (ALT) Depending of Parameter E1	pressure: 200	pressure: 0	pressure: 5000	pressure: Pa
C4 user rights	0	0	3	
C5 extended operation when switching off the control	10	1	240	min
C6 Set point Source (C1)	Intern	Intern	Extern	
Actual setpoint display (C7=OFF) Measured value display (C7=ON)	OFF	OFF	ON	Off/On/Double
C8 Alarm function On/Off (delay)	0	0	60	Sec.
C9 optional Text (Text = E44)	OFF	OFF	ON	OFF/ON
C10 hour meter (Text = E45)	0	0	12	Months
<i>C11 Control 2 Set point Day (NORM)</i> Depending of Parameter E41 <i>Double display (</i>	Pressure: 200	Pressure: 0	Pressure: 5000	Pressure: Pa
<i>C12 Control 2 alternative Set point (ALT)</i> Depending of Parameter E41	Pressure: 200	Pressure: 0	Pressure: 5000	Pressure: Pa
Description				
Menu D = Display				
D1 Info about the Software Version	2.4			
D2 Language	English			GE, EN, ...
D3 Contrast	5			
D4 factory setting				
<i>D5 Storage / Loading of Micro SD Card</i> <i>The maximum memory size at the Micro-</i> <i>SD- Card must not exceed 2Mbyte.</i> <i>Store / Read</i>	Selection if needed			
D6 Model „control“ or „manual control“	„manual control“			

Menu E = Service	Default	Min	Max	Unit
E2 control mode effective direction Reference variable smaller output signal greater = 0 = Normal Reference variable larger output signal greater = 1 = Inverted	0	0	1	
See Illustration control loop	Pressure: 0	0	1	
E3 Temperature sensor control loop 1 select Extern: NTC at terminals 19-20 Volt: Sensor 0-10V at terminals 5-6 NTC10K: NTC at terminals 19-20	Extern			Ext,V,NTC10k
E4 control loop 1 output signal (0=0-10V)	0	0	3	
E5 Relays effective direction (0=NC, 1= NO)	1	0	1	NC=0,NO=1
E6 Relays limit value /threshold	0,1	0,0 V	10,0 V	Volt
E7 Control character control loop1 0=PID 1=XP	0	0	1	
E8 control loop 1 Proportional range	pressure: 100	pressure: 2	pressure: 1000	pressure: Pa
E9 control loop 1 Set point (5V= centred)	5,0	0,1	10,0	Volt
E10 PID P (control loop 1) Proportional range	pressure: 40	1	100	
E11 PID I (control loop 1) Integration time	pressure: 20	0	2000	
E12 PID control loop 1 time (H) @100ms	3	1	10	x100 mSec.
E13 Min. Volt Input	0,0	0,0	10,0	Volt
E14 Max. Volt Input	10,0	0,0	10,0	Volt
E15 Sensor value at min. voltage at Input control loop 1	pressure: 0	pressure: 0	pressure: 5000	pressure: Pa
E16 Sensor value at max. voltage at Input control loop 1	pressure: 500	pressure:0	pressure:5000	pressure: Pa
E17 Min. voltage output control loop 1	0,0	0,0	5,0	Volt
E18 Max. voltage output control loop 1	10,0	5,0	10,0	Volt
E19 Impulse Periods time for selection PWM (D4= 2, 3, 4)	Temp pulse:30	10	250	Sec.
E20 outdoor temperature OFF/ON (NTC2)	OFF	OFF	ON	OFF/ON
E21 outdoor temperature reduction	0	0	500	°C
E22 area min. outdoor temperature reduction	-10 °C	0,0 °C	-25 °C	°C
E23 area max. outdoor temperature reduction	5 °C	-10 °C	15 °C	°C
E24 Intern Temperature sensor correction	0,0	-5,0	+5,0	°C
E25 Sensor min. voltage at input control loop2	0,0	0,0	10,0	Volt
E26 Sensor max. voltage at input control loop 2	10,0	0,0	10,0	Volt
E27 Sensor value at min. voltage at input control loop 2	-20	-20	50	°C
E28 Sensor value at max. voltage at input control loop 2	50	-20	50	°C
E29 control loop 2 OFF = Maximum selection ON = control loop 2 at control output 2	OFF	OFF	ON	OFF/ON
E30 control character control loop 2 0=PID 1=XP 0=PID 1=XP	1	0	1	
E31 control loop 2 Proportional range	1,0	0,5	20	°C
E32 control loop 2 Set point (5V= centred)	5,0	0,1	10,0	Volt
E33 PID P (control loop 2) Proportional range	20	1	100	

E34 PID I (control loop 2) Integration time	200	0	2000	
E35 PID control loop 2 time(H) @100ms	1	1	10	mSec.
E36 Min. voltage output control loop 2	0,0	0,0	5,0	Volt
E37 Max. voltage output control loop	10,0	5,0	10,0	Volt
E38 control mode effective direction Reference variable smaller output signal greater = 0 = Normal Reference variable bigger output signal greater = 1 = Inverted	0	0	1	
E39 is not used	-	-	-	-
E40 Vout2 0=10V constant 1= control loop 2 regardless of control loop 1	0	0	1	
E41 Reg2 input variable (0 = C, 1 = Pa, 2 = ppm)	0	0	2	
E42 Temperature sensor control loop 2 selecting Extern: NTC on terminals 20-21 Volt: Alarm: Alarm, on terminals 20-21 = open Tacho signal max 10V 60Hz (3600 rpm) Switch / PIR1: motion detector terminals 20-21 (Normal / Alternative set point) NTC10K: NTC on terminals 20-21 Switch / PIR2: motion detector terminals 20-21 (Normal / OFF operation) Alarm 2: only display Alarm , on terminals 20-21 = open relay not lock out	Extern	Extern	Alarm2	
E43 Alarm Set point setting	Pressure: 100	Pressure: 2	Pressure: 4000	Pressure: Pa
E44 user Text Name max. 12 characters				
E45 user Text hours max. 6 lines with 12 characters				
E46 Alarm Level Min 0-10V (speedometer Signal)	10	0	50	%
E47 Alarm Level Max 0-10V (speedometer Signal)	60	20	100	%
E48 time motion detector	600	1	3600	Sec.
E49 K-Factor control loop 1 (0= inactive)	0	0	10000	
E50 K-Factor control loop 2 (0= inactive)	0	0	10000	
E52 time-delay of the control When E6 =0 Relay is used for damper actuator function				
E53 Start voltage level control loop 1				
E54 Start voltage level control loop 2				
Menu F = Modbus	Default	Min	Max	Unit
F1 MODBUS Address (1-247)	50	1	247	Address
F2 MODBUS Baud rate OFF, 9600, 19200	0	0	2	
F3 MODBUS Parity EVEN, ODD, NONE	1	1	3	
F4 MODBUS writing ON or only writing OFF	OFF	OFF	ON	

4.2 Parameter Control mode

Control with output 0-10Vdc and Relay

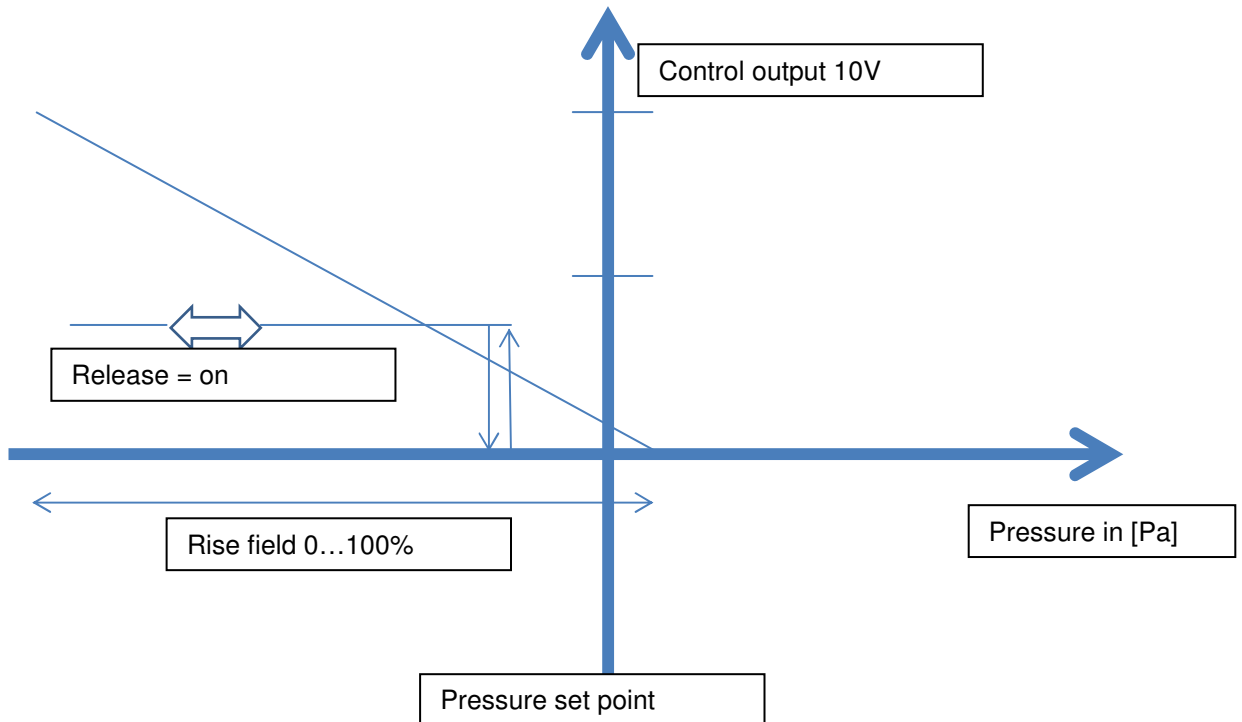

Image: Description control loop effective direction

There are principally two options for the loop: The measurand (reference variable) drops and the control output (manipulated variable) rises or the measurand (reference variable) rises and the control output (manipulated variable) rises.

See example above heating

See example above pressure control fan

The **Parameter E2** sets basically the control mode and the effective direction.

0 = Normal: Measurand (reference variable) is smaller than the set point and the control output increases.

1 = Inverted: Measurand (reference variable) is larger than set point and the control output increases.

The **Parameter E5** sets the effective direction for relay.

0 = (Normal Closed NC)

The relay opens when shortfall or exceedance

1 = (Normal Open NO)

The relay closes when shortfall or exceedance

When the parameter C8 alarm function is activated the parameter E5 relays effective direction is not available.

The **Parameter E6** is the limit value/ threshold for switching or activating the relay.

If the output voltage V_{out1} reaches (control output / manipulated variable) the value (E6) the relay switches on. The area can be from 0 ... 10V (0...100%).

When the parameter C8 alarm function is activated $C8 > 0$ the parameter E6 is not available. This means that the relay will be configurator as alarm relay.

The **Parameter E7** is for the selection of the control character of the loop1.

0 = PID (with Dynamic at control deviation)

1 = XP (simple control)

Alarm function

When the parameter C8 alarm function is activated $C8 > 0$ the parameter Parameter E6 is not available. This means that the relay will be configured as alarm relay.

For the display „Din Alarm“ (Digital Input Alarm) 3 Parameters must interact:

C8 Alarm function ON/OFF (delay >0)

E6 Relay limit value/ threshold =0

E42 Temperature sensor loop 2, selection „Alarm“, terminals 20-21 = open

or selection „Alarm2, terminals 20-21 = open

The Input for the NTC Sensor is used in this case as alarm or as switch input.

The Relay is used for the „Alarm“ selection.

The Relay is used for the selection „Alarm2“not as alarm relay but as operation relay.

When at the same time a damper actuator (with runtime Parameter $E52 > 0$) shall be selected and the alarm message „Din Alarm“(Digital Input Alarm) shall be displayed then the „Alarm2“must be set. Only then the relay remains permanently tightened as control for the damper actuator.

The Parameter E43 must be at setting Pa (pressure, volume flow)= 0, at setting °C (Temperature)= 50, at %r.F. (humidity)= 100 and at ppm (CO₂)= 2500. With this settings it will be avoid that for the alarm the pressure, volume flow is too low and the temperature, the humidity and CO₂ is too high. The alarms would set off the relay which is not the desired effect.

4.3 Parameter List 4-stage speed specification

The Parameter in the Menu D and E Service are protected by the password 5550.

The MultiControl is without active control behaviour.

The MultiControl is suitable only for the speed specification with a voltage output.

Description	Default	Min	Max	Unit
Menu C = User				
C1 Set point Output Level, limited usable in function 4-stage control because selection in the Start display	50	0	100	%
C2 Calendar ON/OFF	OFF	OFF	ON	OFF/ON
C3 period Switch on-Boost	5	0	250	Sec.
C4 User rights, 0= only Parameter D and E have password-protection.	0	0	3	
C5 Extends the operation when switching off the control.	10	1	240	Min
C6 Set point source (internal or external Vin2)	Internal	Internal	External	
C8 Alarm Function On/Off (delay)	0	0	60	Sec.
C9 optional Text (Text = E44)	OFF	OFF	ON	
C10 hour counter (Text = E45) ESC for 3 seconds in display break press and with ENTER confirm for Reset	0	0	12	Months
Description	Default	Min	Max	Unit
Menu D = Display				
D1 Info about Software Version	2.4			
D2 language	English			GE, EN, ...
D3 Contrast	5			
D4 factory setting Warning: Important settings will be change				
D5 storage / Loading of Micro SD Card Maximum memory size for the Micro- SD- Card cannot exceed 2Mbyte. Reading / Writing Menu	Selection if needed			
D6 Model „factory setting 05 4 Stage“	1	1	6	
Description	Default	Min	Max	Unit
Menu E = Service				
E1 Model selection (ON/OFF, Stepless %, 4-Stage)	Depending on settings			
E2 lowest voltage (limit 0-5V)	0	0	50	50 = 5.0V
E3 Highest voltage (limit 5-10V)	100	50	100	50 = 5.0V 100 = 10.0V
E4 Start value at output (1= Min., 2= Max., 3= Last)	3	1	3	
E5 voltage value reverse	OFF	OFF	ON	
E25 minimum voltage director input Vin2 (C6 = external)	0.0	0.0	10.0	Volt

E26 Maximum voltage director input Vin2 (C6 = external)	10.0	0.0	10.0	Volt
E27 Scaling of the minimal voltage of the director in % input Vin2 (C6 = external)	0	0	100	%
E27 Scaling of the maximum voltage of the director in % Input Vin2 (C6 = external)	0	0	100	%
E40 Vout2 (0=10V 1=without usage 3=Offset of Vout1) Different sizes EC- Fans	0	0	2	
E42 Temperature sensor control loop 2 selecting Extern: NTC on terminals 20-21 Volt: Alarm: Alarm, on terminals 20-21 = open Tacho signal max 10V 60Hz (3600 rpm) Switch / PIR1: motion detector terminals 20-21 (Normal / Alternative set point) NTC10K: NTC on terminals 20-21 Switch / PIR2: motion detector terminals 20-21 (Normal / OFF operation) Alarm 2: only display Alarm, on terminals 20-21 = open relay not lock out	External	0	8	
E44 user/ asset text max. 12 characters, approval by C9				abc
E45 hours of operation text max. 12 characters 6 lines, approval by C10				abc
E46 Alarm limit value below, only for speed signal	10	0	50	
E47 Alarm limit value above, only for speed signal	60	50	100	
E48 time delay PIR motion detector	600	1	3600	Sec.
E49 Off-Set Vout2 zu Vout1 Formula $Vout2=Vout1 \times (E49/100)$.	100%	0	200	%
E52 time delay until start of 0-10V Output, Relay starts immediately, when E6 =0 Relay is used for damper actuator function	0	0	240	Sec.
E55 Level Stage 1	25	0	100	%
E56 Level Stage 2	50	0	100	%
E57 Level Stage 3	75	0	100	%
E58 Level Stage 4	100	0	100	%
Description	Default	Min	Max	Unit
Menu F = Modbus				
F1 MODBUS Address (1-247)	50	1	247	Address
F2 MODBUS baud rate AUS, 9600, 19200	0	0	2	
F3 MODBUS Parity EVEN= 1, ODD= 2, NONE= 3	1	1	3	
F4 MODBUS AUS, only read or write	1	1	3	

4.4 Time Program

Menu B: The integrated weekly program allows 10 switching operations per day. The integrated weekly program can be switched on/off in the Menu C with the Parameter C2

A switching state is set for B1 and starts from the reset of the switching state by entering „- - - - „

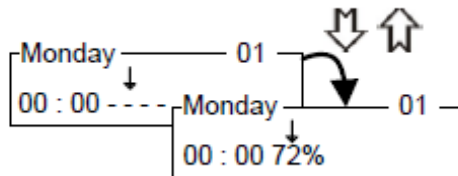

Example of entries in the weekly program:

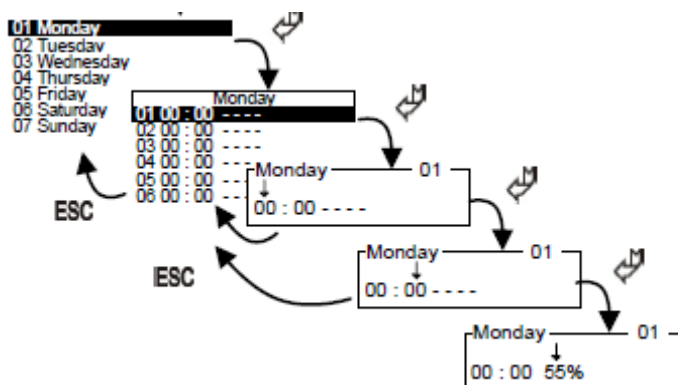

B1 weekly program set point entries

B2 weekly program reset / delete

B3 Copy of a day profile from the weekly program to another day

B4 Time and Date settings

B5 Saving or loading of the weekly program in the MicroSD- memory card

5 Storage, Transport

The control device MultiControl with the Installation housing article number H42-91000, H55-00072 and H55-00073 should not be exposed to condensation or water influence.

Technical Limits

Temperature: 0 to +60°C for the model 24V AC, 0 to +50°C for the model 230V AC

Humidity: non-condensing, without dew

6 Maintenance, Servicing



Maintenance and servicing should only be done by trained and instructed staff and when taking all relevant rules and regulations into consideration!

Usually our Rosenberg MultiControl with the Installation housing or assembly. With the article number H42-91000, H55-00072 and H55-00073 are maintenance free.

When working at the electronic and the switching circuit the guidelines for the electrical safety must be maintained and divide from the voltage. The voltage must be controlled with a two-pole voltage tester.

All screw connections must be controlled and if necessary tighten up before restoration or enable operation.

All changes, inspections, repairs on the electrical connections may only be made by an authorized electrician.

Checking the insulation resistance of supply and electrical protective ground conductor system according to DIN EN 60204 -1 or VDE 0113 -1 4.1 is recommended.

For the maintenance and service the protective conductor system and the automatic shutdown in case of error must always be checked

Electrical fuses can only be replaced but not be repaired or bridged. Only the fuses intended in the electrical circuit diagram can be used

7 Accessories and Field Device

Components	Rosenberg Article number
Duct- Temperature sensor 10K Ω NTC	H42-09926 (H42-09937 22K Ω NTC on request)
Room- Temperature sensor 10K Ω NTC	H42-09902
Outdoor- Temperature sensor 10K Ω NTC	H42-09914
CO ₂ - Sensor, 0 to 2000ppm 24V AC, 0-10V DC Signal	H42-09930 * external power supply necessary
Speed sensor, 24V AC, 0-10V DC Signal	H42-XXXXX, on request
Antifreeze- Thermostat Capillary length 3,0m	FST000-0212N
Differential pressure switch Adjustment range 50 to 500Pa	DDW050-0500N

Components	Rosenberg Article Number
Humidity sensor, 0-100%	H42-09936
24V AC, 0-10V DC Signal	
Differential pressure sensor	H42-00100
with Display	
0 to 1000Pa adjustable	
24V AC, 0-10V DC Signal	

8 Copyright



It is forbidden to copy the manual or parts of it by photomechanical means (copy, micro copy) or to publish it in newspapers and magazines or other media.



If there are further questions after you have read the manual, please consult our sales representative

9 Customer Service, Manufacturer's address



The products of Rosenberg Ventilatoren GmbH are constantly checked for quality and correspond to the relevant regulations.

For all questions regarding our products, consult the originator of your ventilation system at one of our subsidiaries or direct to:

Rosenberg Ventilatoren GmbH
Maybachstraße 1
D-74653 Künzelsau- Gaisbach
Phone: +49 (0)7940/142- 0
Telefax: +49 (0)7940/142- 125
Email: info@rosenberg-gmbh.com
Internet: www.rosenberg-gmbh.com

10 Commissioning Protocol

<input type="checkbox"/> Is the EC- Fan smooth in the switched-off state and free from tension?	
<input type="checkbox"/> Is the flow direction of the EC- Fan correct?	
<input type="checkbox"/> Does the supply voltage of the EC- Fan and the wiring correspond to the nameplate?	
<input type="checkbox"/> Can the air volume and the information on the electricity in the operating point be proved with measurements?	
<input type="checkbox"/> Is the electrical safety according to EN60204-1 shut-down and main switch for the application with the EC-Fans guaranteed? with protective ground conductor, automatic	
<input type="checkbox"/> Are the operating instructions accessible and does the settings of the set points and parameters fit with the application??	
<input type="checkbox"/> Is the Sensor „0-10V in 1 / NTC 1“controlled? The measuring range and the Signal are displayed correctly	Sensor type: _____
<input type="checkbox"/> Is the sensor „0-10V in 2 / NTC 2“controlled? The measuring range and the Signal are displayed correctly	Sensor type: _____

11 Notes

In this field you can enter comments and set points:
